



# Cleaning Air-Cooled Condensers Case Studies

ACC Users Group  
October 4-6, 2016

Mr. Willis Shook  
Conco Services Corp.



# Case 1: Leaking Tubes

## Yellowstone Power Plant Air Cooled Condenser





# Case 1: Leaking Tubes

- Each module contains
  - 1 fan
  - 6 finned tube bundles
- ACC has 10 module consisting of
  - 8 condensing cells
  - 2 reflux cells
- Finned tube bundles have
  - 211 galvanized coated carbon steel oval tubes in a 3 tube arrangement



# Case 1: Leaking Tubes

- The ACC has 10 fans
  - 26 foot
  - 10 bladed
  - 2 speed gear reduced motor
- Fans turn at
  - 125 RPM – fast mode
  - 63 RPM – slow mode
- Fan motors have reverse contacts
  - Reverse fans in severe winter



# Case 1: Leaking Tubes

## Center of ACC





# Case 1: Leaking Tubes

Tubes – Frozen and Degraded from  
Debris Trapped Behind Support Beams





# Case 1: Leaking Tubes

## Frozen Burst Tube





# Case 1: Leaking Tubes

## Holes in Top of Tube Connections to Steam Header







# Case 1: Leaking Tubes

Removal of Outer Tubes –  
Gain Access to Inner Row Tube Leaks





# Case 1: Leaking Tubes

## Leaks in Tubes at Lower Condensate Header Connections

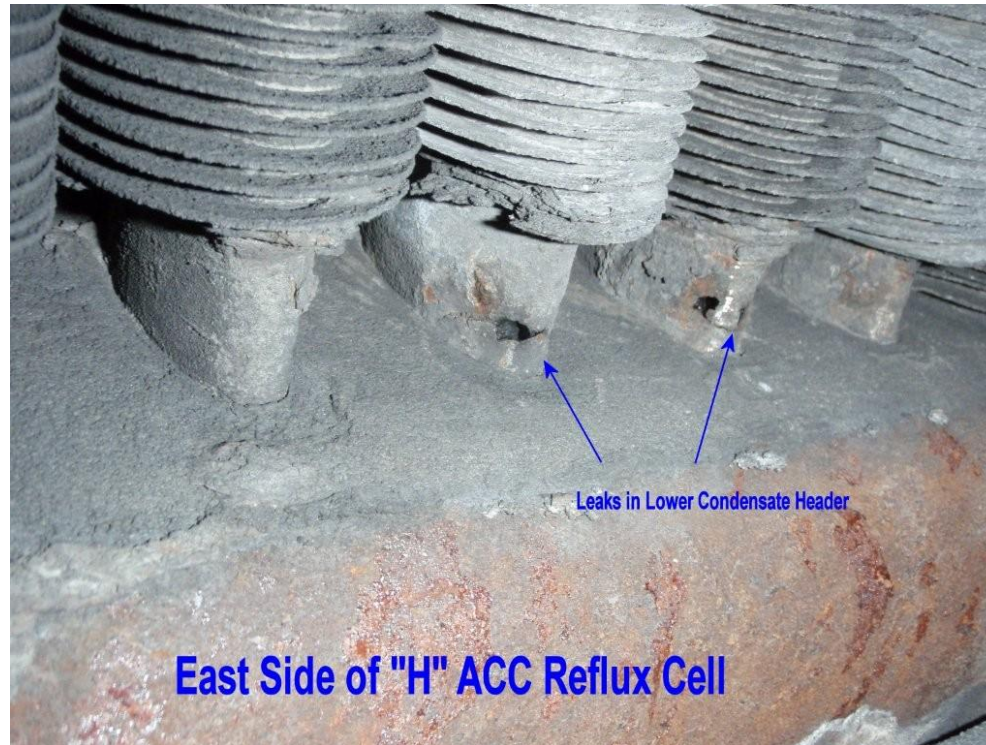



# Case 1: Leaking Tubes

## Environmental problems

- Wind
- Debris
  - Cotton from cottonwood trees
  - Ash
  - Coke dust
  - Other debris
- Cold weather
- Hot weather



# Case 1: Leaking Tubes

## YPP's Solutions

- Use of underground cable shrink wrap and aluminum duct tape
  - Patch major leaks in tubes
- Use of sleeve inserts and outer sleeves
  - Fix tube to header connection leaks
- Sandblasting and pressure washing of tubes
  - Remove debris from finned areas



# Case 1: Leaking Tubes

## YPP's Solutions Continued

- Use of epoxy paints
  - Help preserve and close pin hole leaks
    - Steam header connections
    - Condensate headers
- Wind Fence
- Wind Wall



# Case 1: Leaking Tubes

## Cable Shrink Wrap – Repair Major Holes in Tubes





# Case 1: Leaking Tubes

## Tube Sleeve Inserts and Outer Couplers

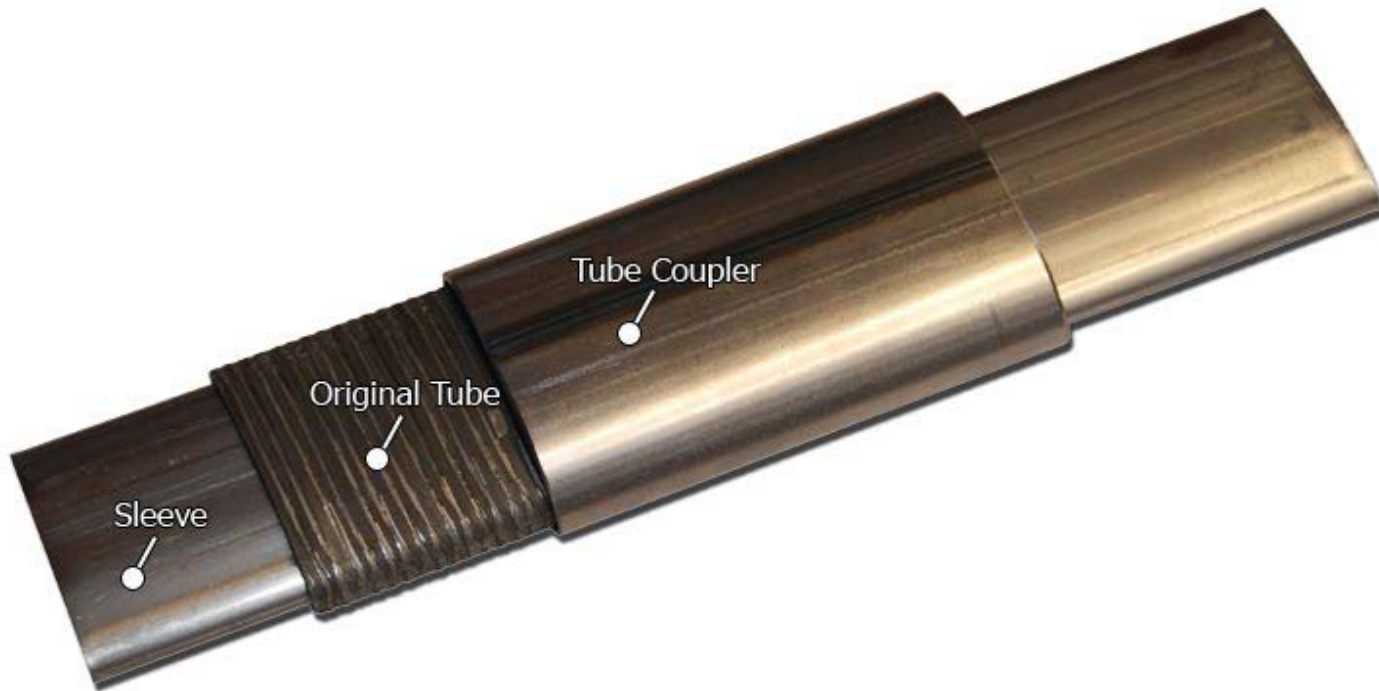



# Case 1: Leaking Tubes

## Epoxy Paint

**Holes in Tube Headers**



**Holes Repaired and Epoxy Painted**







# Case 1: Leaking Tubes

## Wind Fence





# Case 1: Leaking Tubes

## Wind Wall





## Case 2: Cleaning with Biodegradable Degreaser

### Plant Conditions

- Plant burns coker gas from refinery
- Steam produced sent back to refinery
- Harsh winter partially froze coker gas line
  - Created blockage in the line
  - High pressure behind the blockage



## Case 2: Cleaning with Biodegradable Degreaser

### Problem

- When blockage broke free
  - Pressurized oil leaked through the Loop Seal Stack
  - Oil covered
    - Outside surface of the ACC unit
    - Surrounding areas



## Case 2: Cleaning with Biodegradable Degreaser

### Oil on Surface of Unit

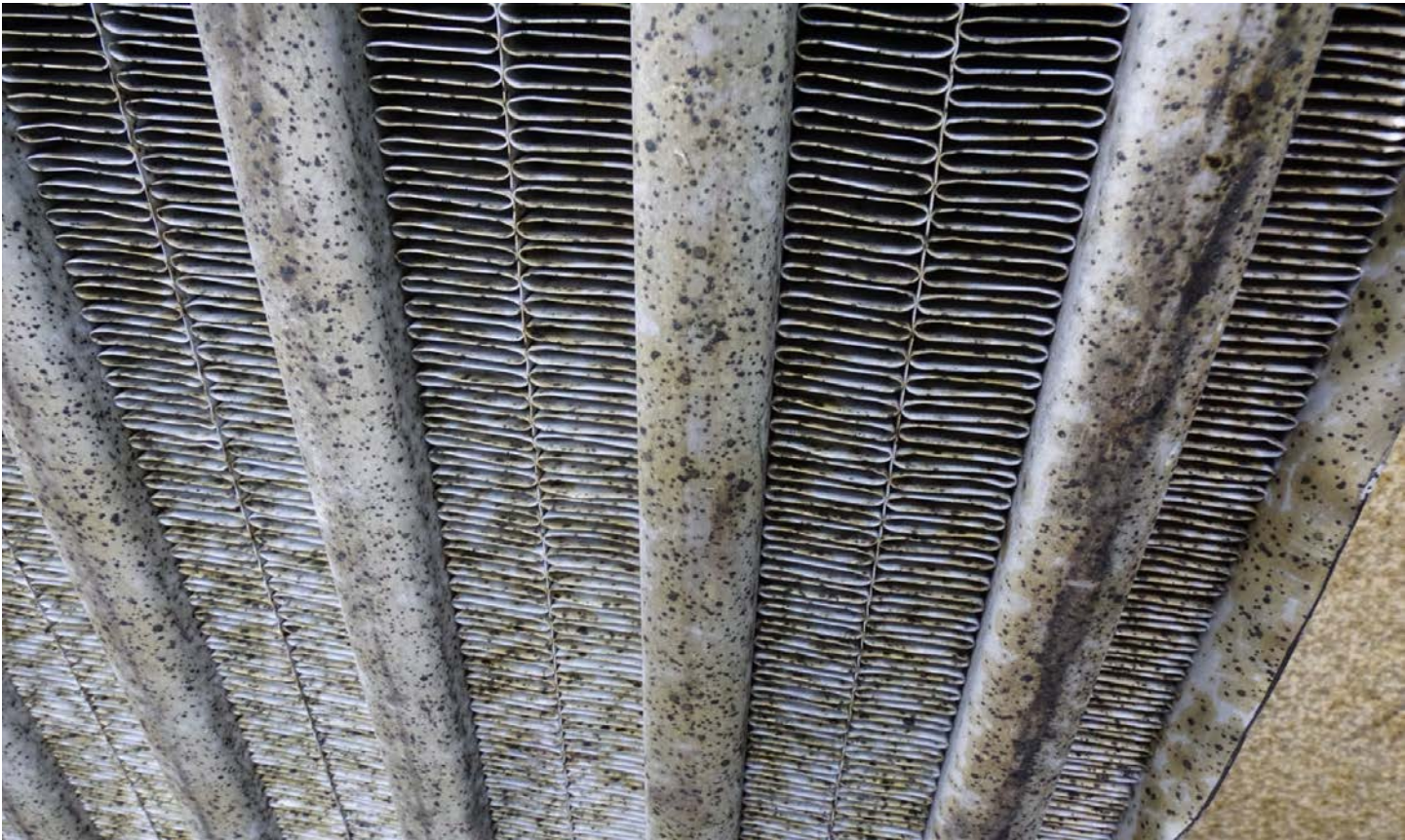



# Case 2: Cleaning with Biodegradable Degreaser

## Oil Covers Unit

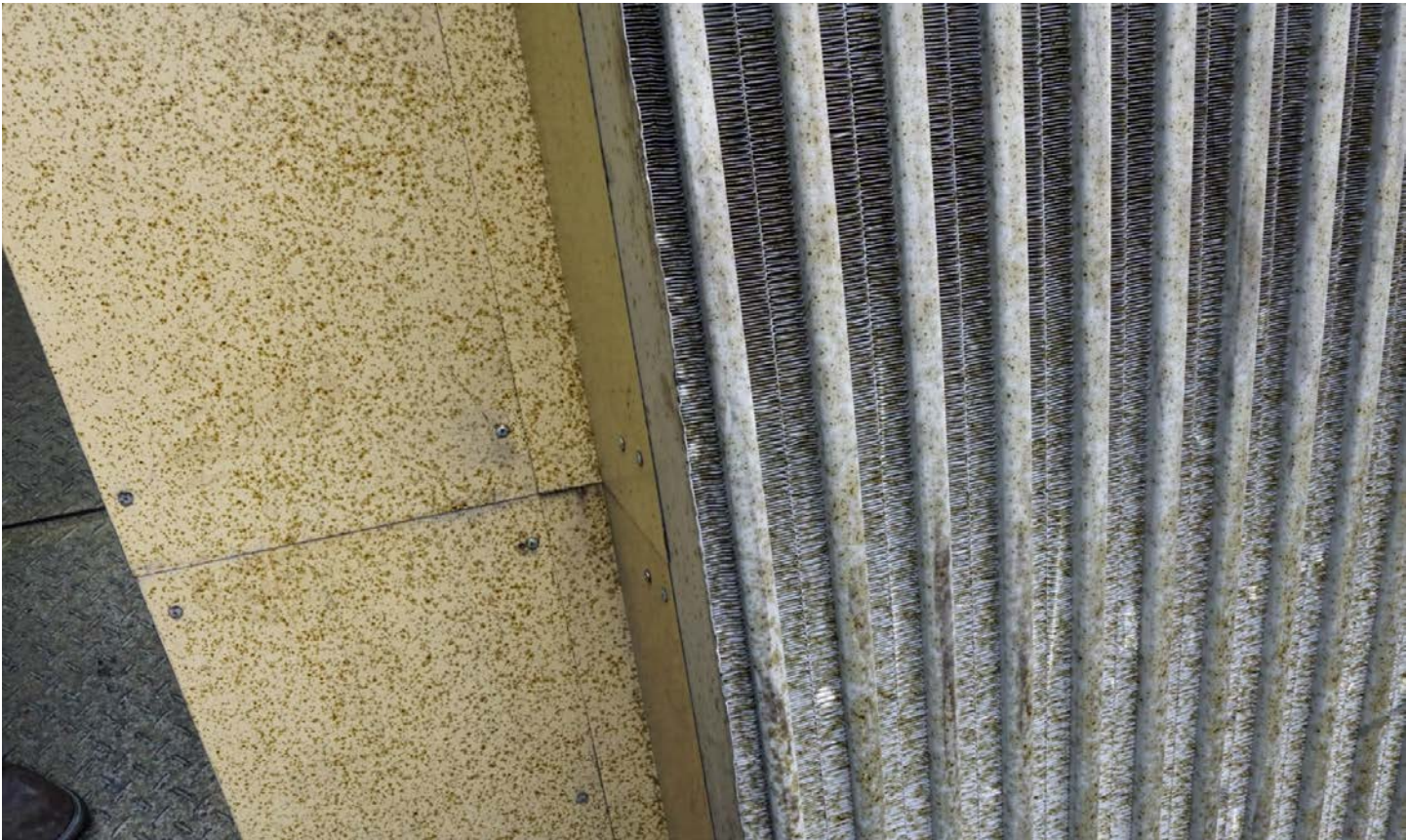



## Case 2: Cleaning with Biodegradable Degreaser

### Additional Problem

- Truck spilled fly ash near the ACC unit
- Ash sucked into the ACC fans
- Under side of fins coated with oil and ash
- Oil acted like a glue



## Case 2: Cleaning with Biodegradable Degreaser

### Ash Covers Fins Underneath Unit

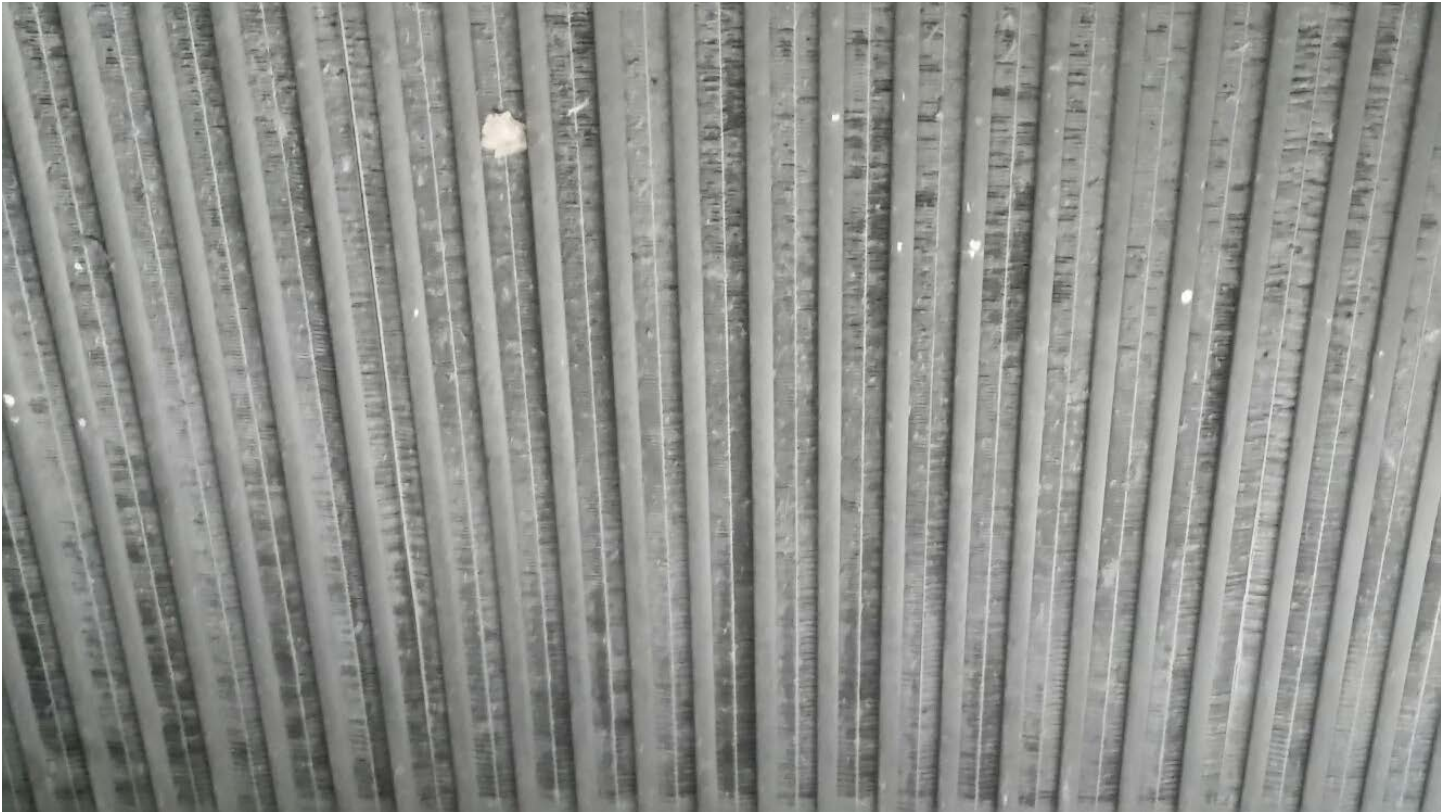





## Case 2: Cleaning with Biodegradable Degreaser

### Initial Attempt to Clean

- Plant attempted to clean unit using:
  - Cleaning system installed with unit
  - High pressure water
- Cleaning was unsuccessful



## Case 2: Cleaning with Biodegradable Degreaser

### Cleaning using De-Greaser

- ACC cleaning system brought to plant
  - Capable of higher pressure – adjustable
- Bundles presoaked with bio-degradable degreaser
- Unit cleaned using a higher pressure with ACC cleaning system



# Case 2: Cleaning with Biodegradable Degreaser

## ACC Cleaning System





## Case 2: Cleaning with Biodegradable Degreaser

### ACC Cleaning System: Riding the Rails





## Case 2: Cleaning with Biodegradable Degreaser

### View from Inside Unit





# Case 2: Cleaning with Biodegradable Degreaser

Results

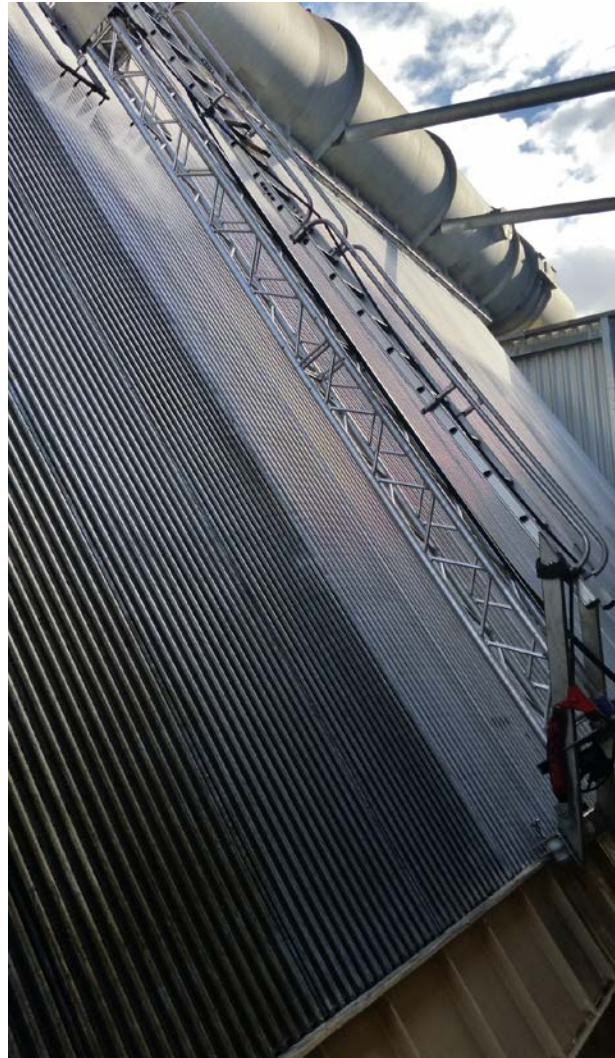



# Case 2: Cleaning with Biodegradable Degreaser

Results





# Case 2: Cleaning with Biodegradable Degreaser

## Results







## Case 3: ACC Vertical Unit Cleaning Solution

### Haverhill

- Issue – unable to effectively clean unit
- Standard ACC cleaning system did not fit
- Had to modify entire unit
- Cleaning system had to fit between fans and unit



## Case 3: ACC Vertical Unit Cleaning Solution

- Vertical ACC unit
- Consists of 78 fans
- Rectangular structure
- Fans on each of the 4 sides
- Fans are 2 high on each side
- ACC structure on the top of Main Building



# Case 3: ACC Vertical Unit Cleaning Solution





# Case 3: ACC Vertical Unit Cleaning Solution





# Case 3: ACC Vertical Unit Cleaning Solution





# Case 3: ACC Vertical Unit Cleaning Solution

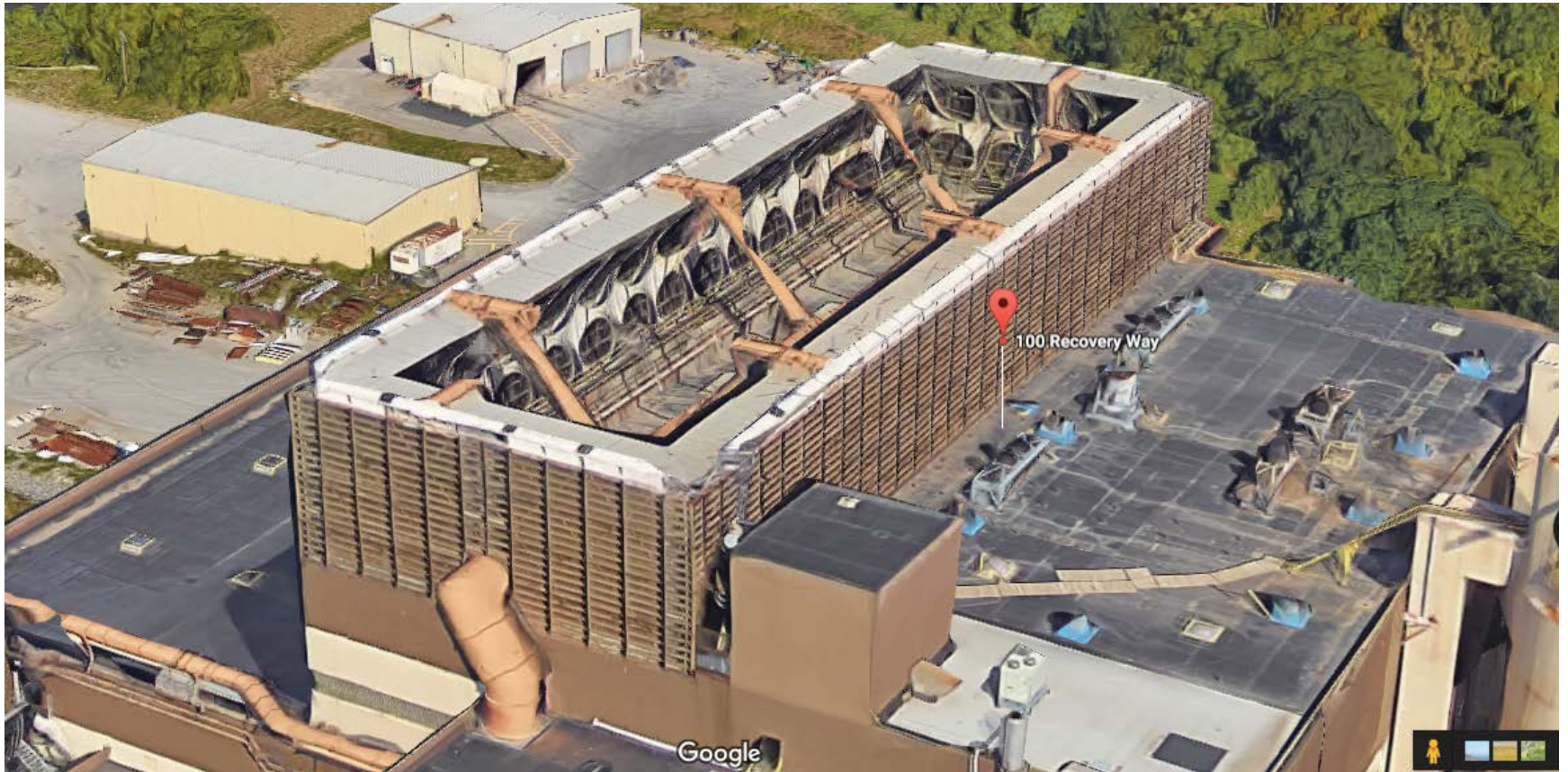



# Case 3: ACC Vertical Unit Cleaning Solution

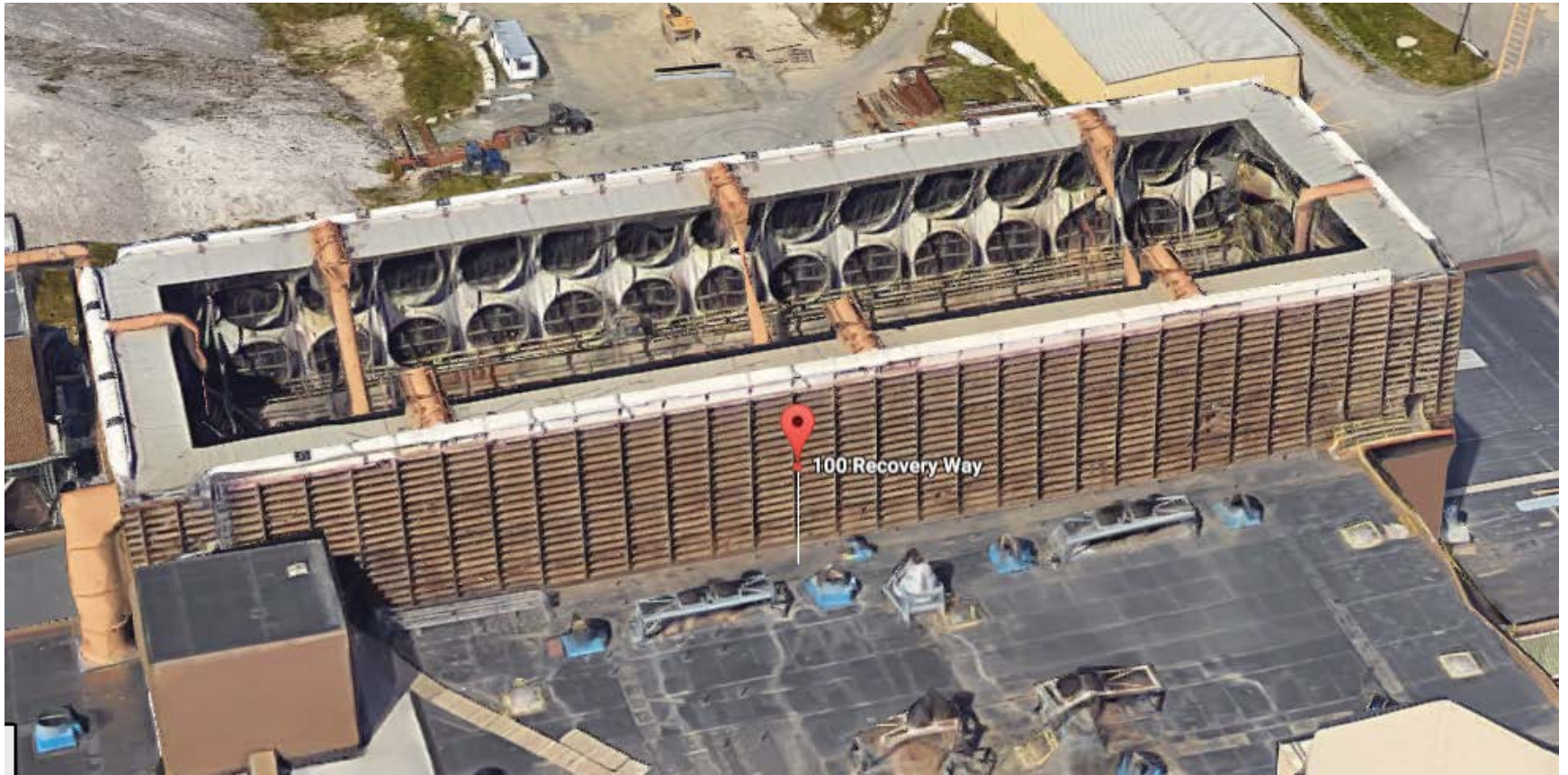



# Case 3: ACC Vertical Unit Cleaning Solution





# Standard ACC Cleaning Equipment

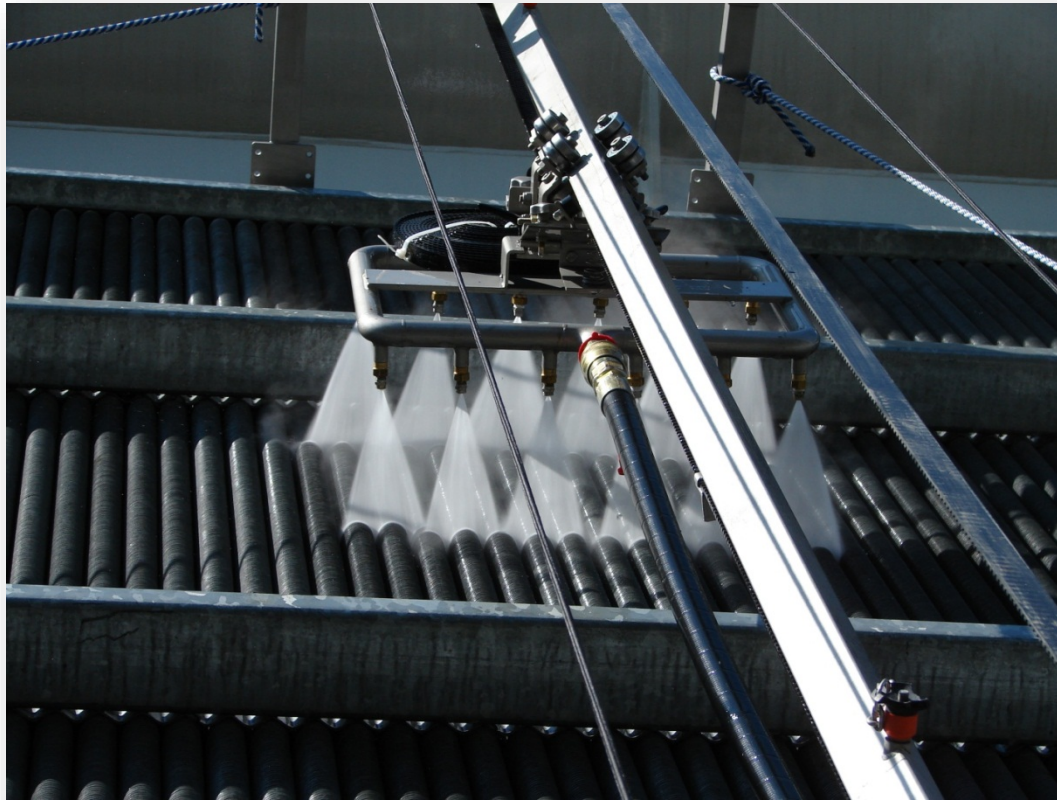



# Case 3: ACC Vertical Unit Cleaning Solution

## ACC System Modifications

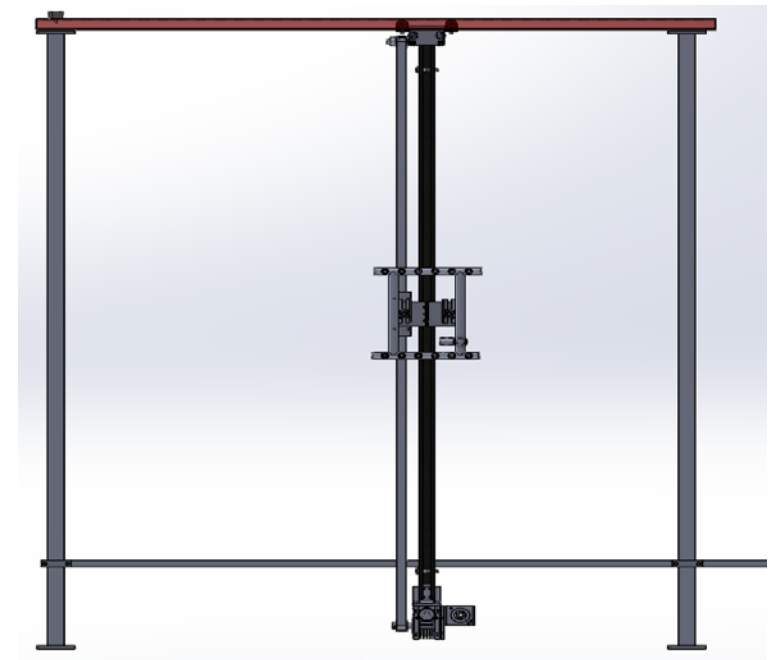
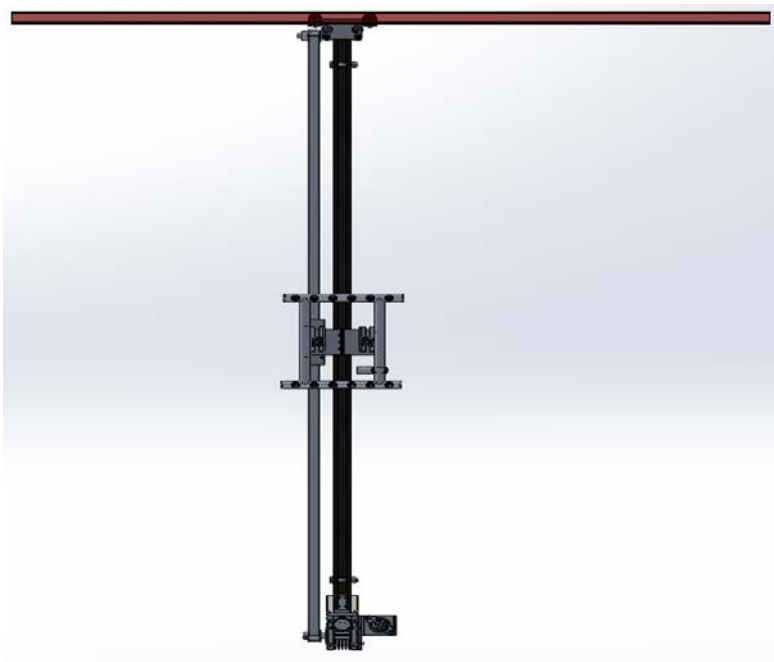



# Case 3: ACC Vertical Unit Cleaning Solution

## ACC System Installation

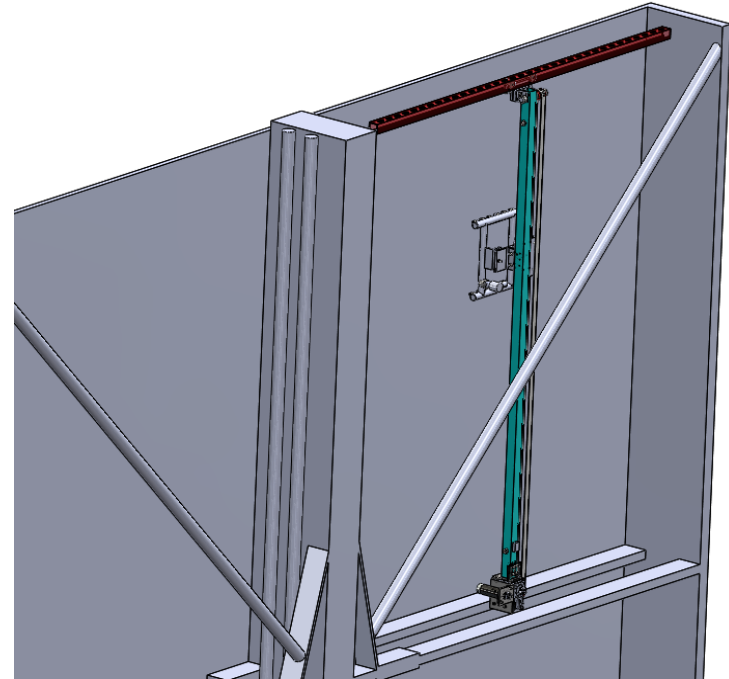
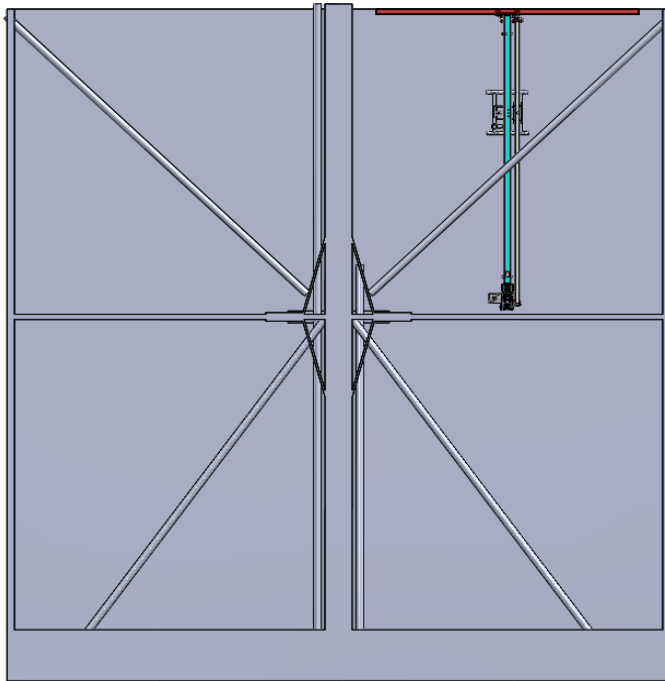



# Case 3: ACC Vertical Unit Cleaning Solution

## ACC System Installation

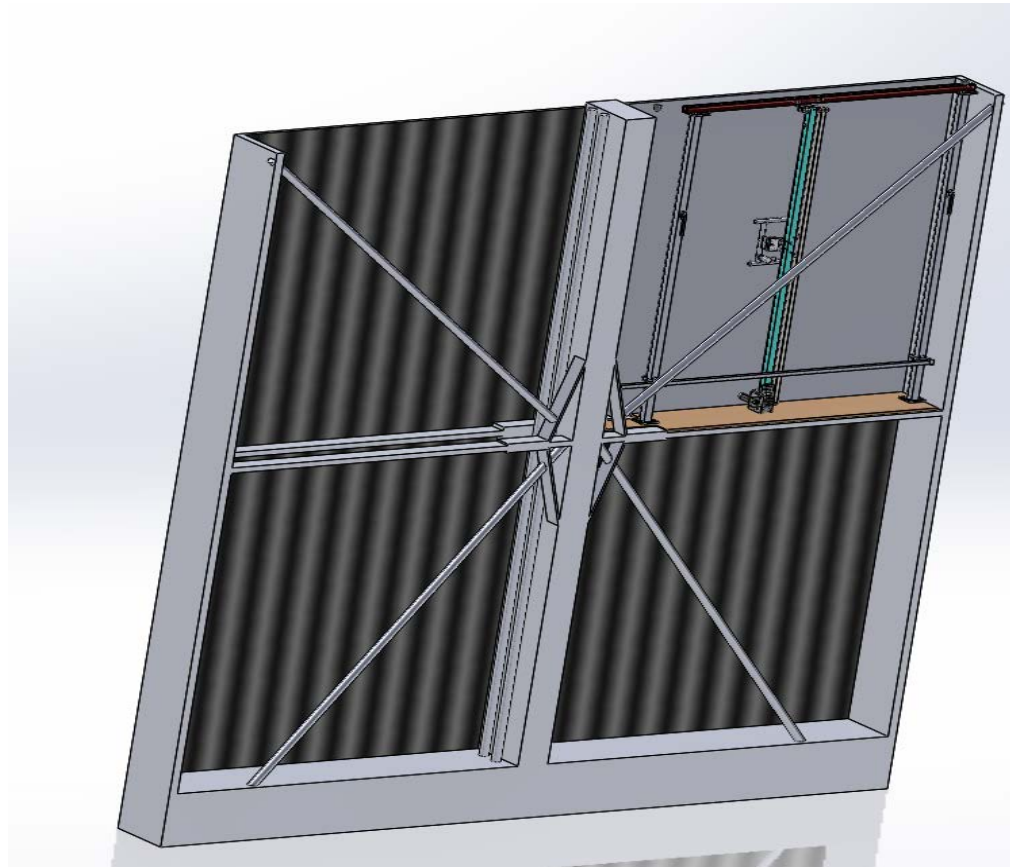



# Case 3: ACC Vertical Unit Cleaning Solution

## ACC System Installation

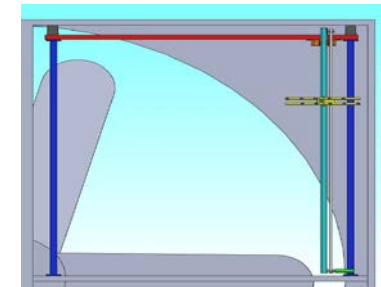
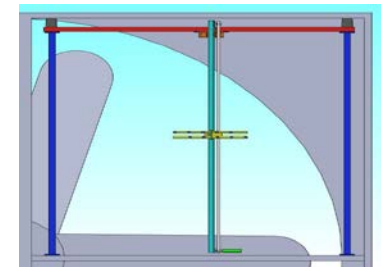
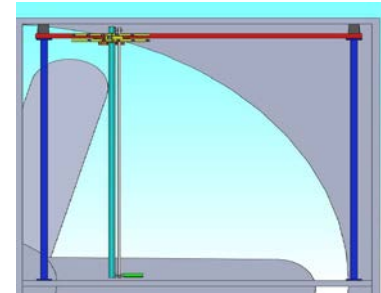
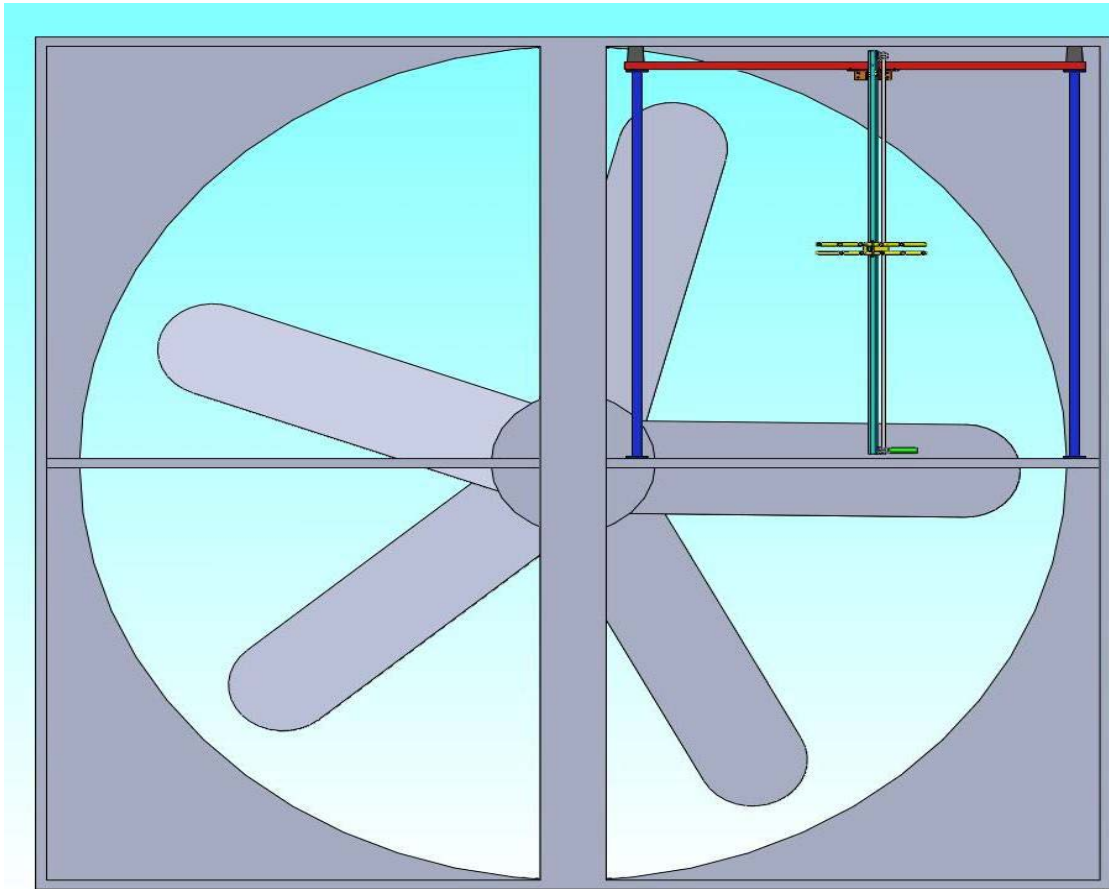



# Questions

